

Makita

アメリカ

Electronic Jig Saw

MODEL 4303C

INSTRUCTION MANUAL

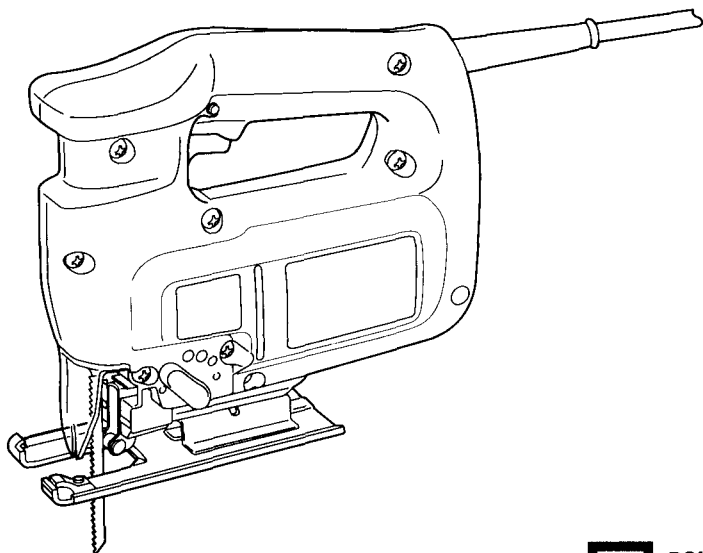

 **DOUBLE INSULATION**

SPECIFICATIONS

Length of stroke	Max. cutting capacities		Strokes per minute	Overall length	Net weight
	Wood	Steel			
26 mm (1")	60 mm (2-3/8")	10 mm (3/8")	1,000 - 3,000	219 mm (8-5/8")	2.5 kg (5.5 lbs)

- Manufacturer reserves the right to change specifications without notice.
- Note: Specifications may differ from country to country.

WARNING: For your personal safety, READ and UNDERSTAND before using.
SAVE THESE INSTRUCTIONS FOR FUTURE REFERENCE.

IMPORTANT SAFETY INSTRUCTIONS

(For All Tools)

WARNING: WHEN USING ELECTRIC TOOLS, BASIC SAFETY PRECAUTIONS SHOULD ALWAYS BE FOLLOWED TO REDUCE THE RISK OF FIRE, ELECTRIC SHOCK, AND PERSONAL INJURY, INCLUDING THE FOLLOWING:

READ ALL INSTRUCTIONS.

1. **KEEP WORK AREA CLEAN.** Cluttered areas and benches invite injuries.
2. **CONSIDER WORK AREA ENVIRONMENT.** Don't use power tools in damp or wet locations. Keep work area well lit. Don't expose power tools to rain. Don't use tool in presence of flammable liquids or gases.
3. **KEEP CHILDREN AWAY.** All visitors should be kept away from work area. Don't let visitors contact tool or extension cord.
4. **STORE IDLE TOOLS.** When not in use, tools should be stored in dry, and high or locked-up place — out of reach of children.
5. **DON'T FORCE TOOL.** It will do the job better and safer at the rate for which it was intended.
6. **USE RIGHT TOOL.** Don't force small tool or attachment to do the job of a heavy-duty tool. Don't use tool for purpose not intended; for example, don't use circular saw for cutting tree limbs or logs.
7. **DRESS PROPERLY.** Don't wear loose clothing or jewelry. They can be caught in moving parts. Rubber gloves and non-skid footwear are recommended when working outdoors. Wear protective hair covering to contain long hair.
8. **USE SAFETY GLASSES.** Also use face or dust mask if cutting operation is dusty.
9. **DON'T ABUSE CORD.** Never carry tool by cord or yank it to disconnect from receptacle. Keep cord from heat, oil, and sharp edges.
10. **SECURE WORK.** Use clamps or a vise to hold work. It's safer than using your hand and it frees both hands to operate tool.
11. **DON'T OVERREACH.** Keep proper footing and balance at all times.
12. **MAINTAIN TOOLS WITH CARE.** Keep tools sharp and clean for better and safer performance. Follow instructions for lubricating and changing accessories. Inspect tool cords periodically and if damaged, have repaired by authorized service facility. Inspect extension cords periodically and replace if damaged. Keep handles dry, clean, and free from oil and grease.
13. **DISCONNECT TOOLS.** When not in use, before servicing, and when changing accessories, such as blades, bits, cutters.

- 14. **REMOVE ADJUSTING KEYS AND WRENCHES.** Form habit of checking to see that keys and adjusting wrenches are removed from tool before turning it on.
- 15. **AVOID UNINTENTIONAL STARTING.** Don't carry tool with finger on switch. Be sure switch is OFF when plugging in.
- 16. **EXTENSION CORDS.** Make sure your extension cord is in good condition. When using an extension cord, be sure to use one heavy enough to carry the current your product will draw. An undersized cord will cause a drop in line voltage resulting in loss of power and overheating. Table 1 shows the correct size to use depending on cord length and nameplate ampere rating. If in doubt, use the next heavier gage. The smaller the gage number, the heavier the cord.

TABLE 1 MINIMUM GAGE FOR CORD SETS

			Total Length of Cord in Feet			
			0 – 25	26 – 50	51 – 100	101 – 150
Ampere Rating More Than	–	Not More Than	A W G			
0	–	6	18	16	16	14
6	–	10	18	16	14	12
10	–	12	16	16	14	12
12	–	16	14	12	Not Recommended	

- 17. **OUTDOOR USE EXTENSION CORDS.** When tool is used outdoors, use only extension cords intended for use outdoors and so marked.
- 18. **STAY ALERT.** Watch what you are doing, use common sense. Don't operate tool when you are tired.
- 19. **CHECK DAMAGED PARTS.** Before further use of the tool, a guard or other part that is damaged should be carefully checked to determine that it will operate properly and perform its intended function. Check for alignment of moving parts, binding of moving parts, breakage of parts, mounting, and any other conditions that may affect its operation. A guard or other part that is damaged should be properly repaired or replaced by an authorized service center unless otherwise indicated elsewhere in this instruction manual. Have defective switches replaced by authorized service center. Don't use tool if switch does not turn it on and off.
- 20. **GUARD AGAINST ELECTRIC SHOCK.** Prevent body contact with grounded surfaces. For example; pipes, radiators, ranges, refrigerator enclosures.
- 21. **REPLACEMENT PARTS.** When servicing, use only identical replacement parts.
- 22. **POLARIZED PLUGS.** To reduce the risk of electric shock, this equipment has a polarized plug (one blade is wider than the other). This plug will fit in a polarized outlet only one way. If the plug does not fit fully in the outlet, reverse the plug. If it still does not fit, contact a qualified electrician to install the proper outlet. Do not change the plug in any way.

VOLTAGE WARNING: Before connecting the tool to a power source (receptacle, outlet, etc.) be sure the voltage supplied is the same as that specified on the nameplate of the tool. A power source with voltage greater than that specified for the tool can result in **SERIOUS INJURY** to the user — as well as damage to the tool. If in doubt, **DO NOT PLUG IN THE TOOL**. Using a power source with voltage less than the nameplate rating is harmful to the motor.

ADDITIONAL SAFETY RULES

- 1. Avoid cutting nails. Inspect for and remove all nails from the workpiece before operation.**
- 2. Don't cut hollow pipe.**
- 3. Do not cut oversize workpiece.**
- 4. Check for the proper clearance beneath the workpiece before cutting so that the blade will not strike the floor, workbench, etc.**
- 5. Hold the tool firmly.**
- 6. Make sure the blade is not contacting the workpiece before the switch is turned on.**
- 7. Keep hands away from moving parts.**
- 8. When cutting through walls, floors or wherever "live" electrical wires may be encountered, DO NOT TOUCH ANY METAL PARTS OF THE TOOL! Hold the tool only by the insulated grasping surfaces to prevent electric shock if you cut through a "live" wire.**
- 9. Do not leave the tool running. Operate the tool only when hand-held.**
- 10. Always switch off and wait for the blade to come to a complete stop before removing the blade from the workpiece.**
- 11. Do not touch the blade or the workpiece immediately after operation; they may be extremely hot and could burn your skin.**

SAVE THESE INSTRUCTIONS.

Installing Makita jig saw blade

CAUTION:

Always be sure that the tool is switched off and unplugged before installing or removing the blade.

Use the hex wrench to loosen the bolt.

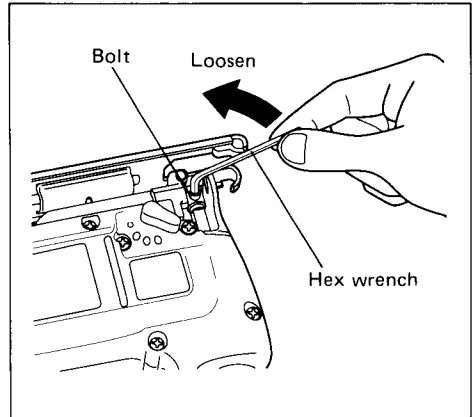

With the blade teeth facing forward, insert the blade into the blade holder as far as it will go.

Make sure that the back edge of the blade fits into the roller and tighten the bolt securely with the hex wrench.

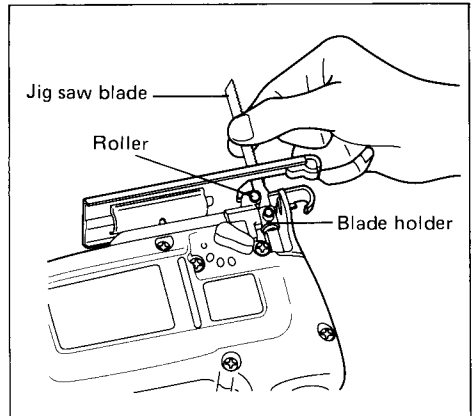

CAUTION:

Use a lubricant or cutting oil between the blade and roller when cutting iron or composition board, etc. Failure to do so will shorten the service life of your blade and roller.

Installing universal shank jig saw blade

CAUTION:

Always be sure that the tool is switched off and unplugged before installing or removing the blade.

If the universal blade clamp is used, you can use blades of other makes which have a universal shank like the one shown in the figure, with a blade width of 6.35 mm (1/4").

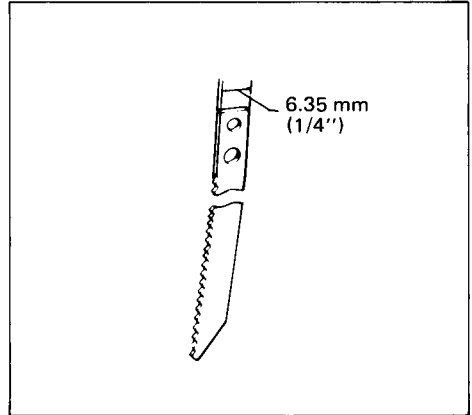

Insert the blade into the blade holder as far as it will go. Make sure that the end of the blade shank reaches the bottom of the inner slit and tighten the bolt securely with the hex wrench.

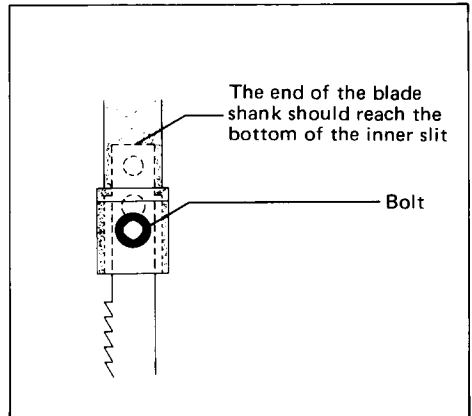

Straight line or orbital cutting action

Conventional jig saws cut with a straight line action, that is, the blade moves only up and down in a straight line. Your saw also cuts in this manner but, for softer workpieces, an orbital cutting action can be selected. Soft workpieces like wood and plastic permit deep penetration of individual saw teeth. The orbital action thrusts the blade forward on the cutting stroke and greatly increases cutting speed over conventional jig saws. Harder workpieces like metal should be cut using the straight line cutting action or a very low orbital setting. To select straight line or orbital cutting, adjust the number on the saw.

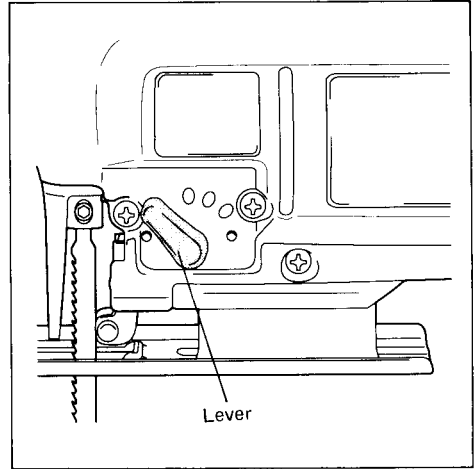

- Position 0 — For cutting in mild steel, stainless steel and plastics.
For clean cuts in wood and plywood.
- Position I — For cutting in mild steel, aluminum and hard wood.
- Position II — For cutting in wood and plywood.
For fast cutting in aluminum and mild steel.
- Position III — For fast cutting in wood and plywood.

Switch action

To start the tool, simply pull the trigger. Release the trigger to stop. For continuous operation, pull the trigger and then push in the lock button. To stop the tool from the locked position, pull the trigger fully, then release it.

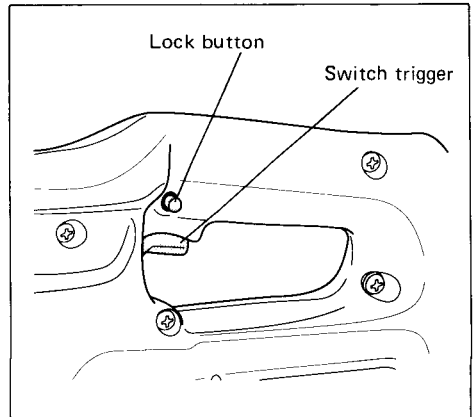

CAUTION:

Before plugging in the tool, always check to see that the switch trigger actuates properly and returns to the "OFF" position released.

Speed change

To adjust the tool speed, turn the speed change dial. The tool speed can be adjusted between 1,000 and 3,000 strokes per minute.

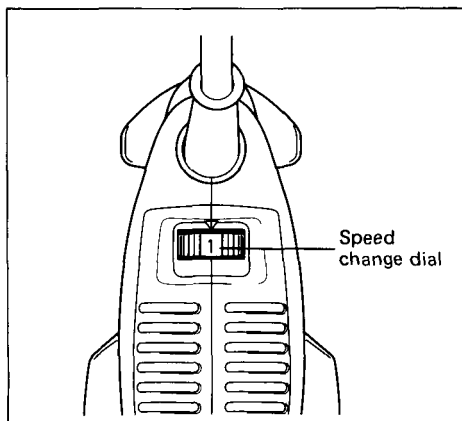

The reference table on the right denotes the relationship between the number settings on the speed change dial and the approximate strokes per minute at that setting.

Number	Strokes per minute
1	1,000
}	}
2	1,200
}	}
3	1,700
}	}
4	2,200
}	}
5	2,700
}	}
6	3,000

Refer to the table on the right to select suggested speed for the workpiece to be cut. However, proper speed may differ depending upon the type or thickness of the workpiece.

Workpiece	Number
Wood	5 ~ 6
Mild steel	3 ~ 6
Stainless steel	3 ~ 4
Aluminum	2 ~ 3
Plastics	1 ~ 4

In general, higher speeds will allow you to cut a workpiece faster but the service life of the blade will be reduced.

CAUTION:

Adjust the speed change dial only within the range of numbers 1 through 6. Do not force the dial beyond this range.

Operation

Turn the tool on and wait until the blade attains full speed. Then rest the base flat on the workpiece and gently move the tool forward along the previously marked cutting line. When cutting curves, advance the tool very slowly.

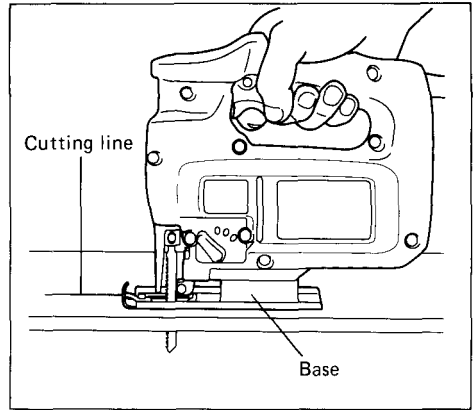

CAUTION:

Failure to hold the tool base flush with the workpiece may cause blade breakage.

Bevel cutting

With the base tilted, you can make bevel cuts at any angle between 0° and 45° (left or right).

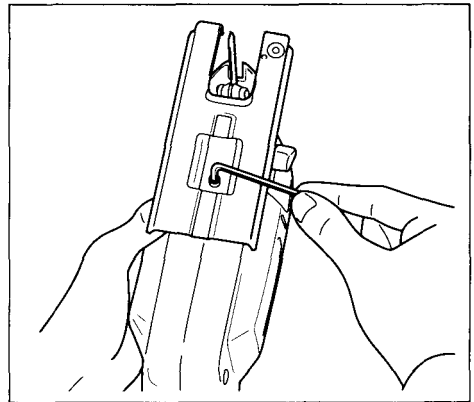

Loosen the bolt on the back of the base with the hex wrench and slide the base backwards. Tilt the base to the desired angle. The edge of the housing indicates the bevel angle.

Then check the contact between the back edge of the blade and the roller.

Now tighten the bolt securely on the back of the base.

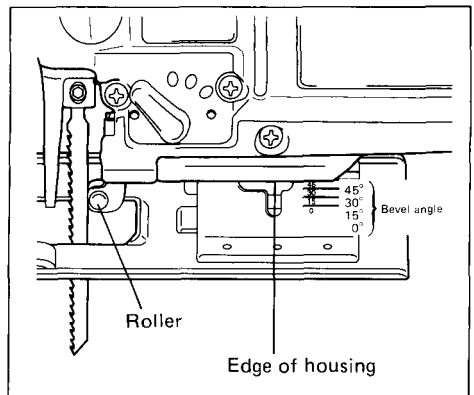

Front flush cuts

Loosen the bolt on the back of the base with the hex wrench, then slide the base backwards. Check the contact between the back edge of the blade and the roller, then secure the bolt.

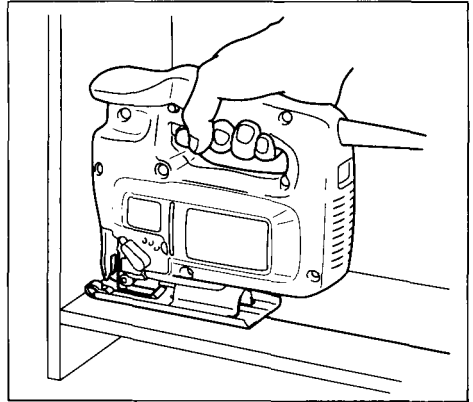

Plunge cutting

Starting a cut at other than the edge of the workpiece without first drilling a starting hole requires a "plunge cut". This can be accomplished by tipping the tool forward until the front end of the base rests against the workpiece. Switch the tool on and lower the back end of the tool slowly, gradually allowing the blade to saw through the workpiece until the base is able to sit flat on the workpiece. You may then proceed forward with the cut in a normal manner.

If using a drill for a starting hole, bore a hole over 12 mm (1/2") in diameter. Then insert the blade in it and proceed.

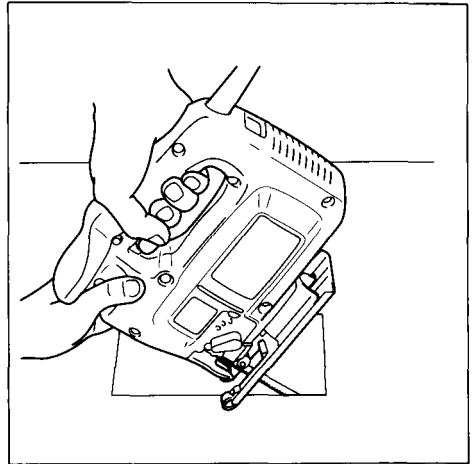

Finishing edges

To trim edges or make dimensional adjustments run the blade lightly along the cut edges.

For smoother cutting of plywood or other workpieces with easily splintered surfaces, transparent tape may be used over your cutting line.

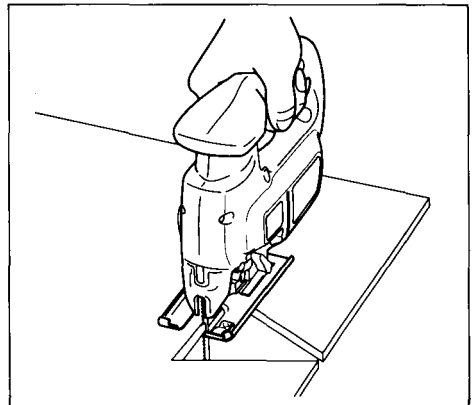

Using guide rule (Rip fence)

When cutting widths of under 150 mm (6'') repeatedly, use of the guide rule will assure fast, clean, straight cuts.

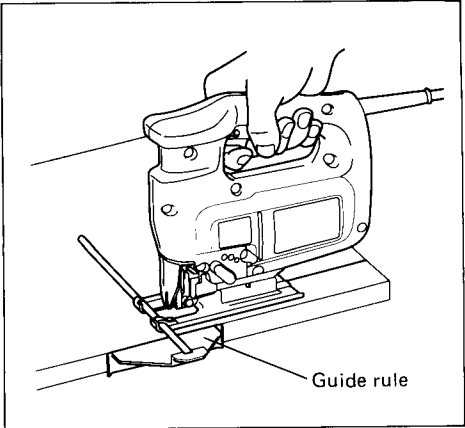

To attach the guide rule (rip fence), secure the rule holder to the base with the screw (do not tighten).

Insert the guide rule between the base and the rule holder. Now tighten the screw with the hex wrench.

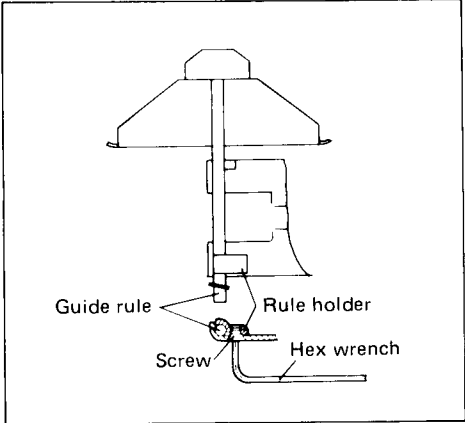

Using circular guide

Use of the circular guide insures clean, smooth cutting of circles (radius; under 200 mm; 7-7/8'') and arcs.

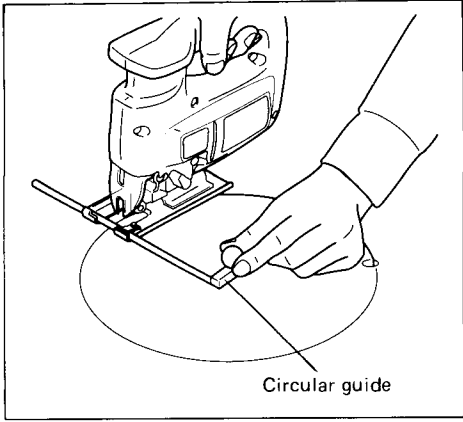

To attach the circular guide, use the pin, inserting it in the center hole (arrow) and secure it with the threaded knob. Then slide the base of the tool forwards. The circular guide attaches to the base of the tool in the same manner as the guide rule (rip fence).

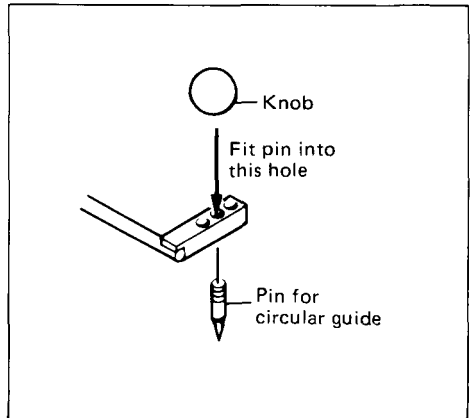

Metal cutting

Always use a suitable coolant (cutting oil) when cutting metal. Failure to do so will cause significant blade wear.

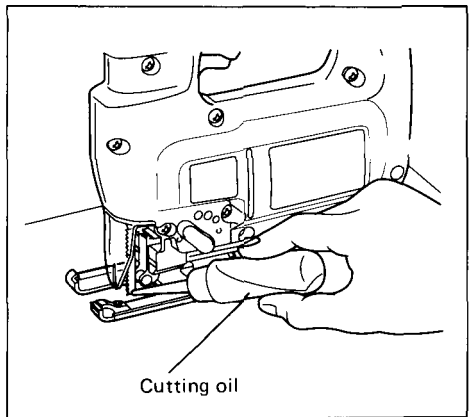

The underside of the workpiece can be greased instead of using a coolant.

MAINTENANCE

CAUTION:

Always be sure that the tool is switched off and unplugged before attempting to perform inspection or maintenance.

To maintain product SAFETY and RELIABILITY, repairs, carbon brush inspection and replacement, any other maintenance or adjustment should be performed by Makita Authorized or Factory Service Centers, always using Makita replacement parts.

ACCESSORIES

CAUTION:

These accessories or attachments are recommended for use with your Makita tool specified in this manual. The use of any other accessories or attachments might present a risk of injury to persons. The accessories or attachments should be used only in the proper and intended manner.

An exception: Universal shank jig saw blades with a thickness of 1 mm – 1.25 mm (1/32" – 3/64") and a length of 58 mm – 82 mm (2-9/32" – 3-7/32").

• Circular guide assembly

Part No. 123030-5



• Guide rule (Rip fence)

Part No. 164113-2

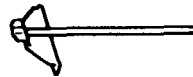

• Hex wrench 3

Part No. 783201-2



• Jig saw blade (Packed 5 each)



Blade type	Part No.	Teeth per inch	Effective cutting blade length	Blade type	Part No.	Teeth per inch	Effective cutting blade length
No. 51	792428-3	24	65 mm (2-1/2")	No. B-17	792469-9	6	70 mm (2-3/4")
No. 58	792429-1	8	80 mm (3-1/8")	No. B-18	792470-4	14	45 mm (1-3/4")
No. 59	792430-6	8	80 mm (3-1/8")	No. B-19	792471-2	12	65 mm (2-1/2")
No. B-10	792529-7	9	80 mm (3-1/8")	No. B-21	792472-0	12	75 mm (3")
No. B-11	792463-1	9	75 mm (3")	No. B-22	792473-8	24	50 mm (2")
No. B-12	792464-9	6	80 mm (3-1/8")	No. B-23	792474-6	14	50 mm (2")
No. B-13	792465-7	8	80 mm (3-1/8")	No. B-24	792475-4	32	50 mm (2")
No. B-14	792466-5	18	50 mm (2")	No. B-25	792476-2	9	75 mm (3")
No. B-15	792467-3	12	50 mm (2")	No. B-26	792477-0	9	70 mm (2-3/4")
No. B-16	792468-1	6	80 mm (3-1/8")	No. B-27	792478-8	24	50 mm (2")

(Note)

Refer to the next page for "Application" of each blade.

• Jig saw blade

Blade type	Application				
	Wood and plywood	Plastics	Aluminum	Mild steel	Feature
No. 51	—	1.5 – 3 mm thick (1/16" – 1/8") H	1 – 6 mm thick (3/64" – 1/4")	1 – 3 mm thick (3/64" – 1/8")	Also ideal for cutting stainless steel.
No. 58	4 – 60 mm thick (5/32" – 2-3/8")	4 – 60 mm thick (5/32" – 2-3/8") S	—	—	For fast cutting.
No. 59	4 – 30 mm thick (5/32" – 1-1/8")	4 – 30 mm thick (5/32" – 1-1/8") S	—	—	For fast finish work.
No. B-10	3 – 60 mm thick (1/8" – 2-3/8")	3 – 60 mm thick (1/8" – 2-3/8") S	—	—	For fast finish work, especially in plywood.
No. B-11	3 – 30 mm thick (1/8" – 1-1/8")	3 – 50 mm thick (1/8" – 2") S	—	—	For fast finish work.
No. B-12	5 – 60 mm thick (13/64" – 2-3/8")	5 – 60 mm thick (13/64" – 2-3/8") S	—	—	For fast finish work.
No. B-13	4 – 60 mm thick (5/32" – 2-3/8")	4 – 60 mm thick (5/32" – 2-3/8") S	—	—	For roughing-in work.
No. B-14	2 – 30 mm thick (5/64" – 1-1/8")	2 – 30 mm thick (5/64" – 1-1/8") H	—	—	Ideal for cutting thin materials.
No. B-15	3 – 30 mm thick (1/8" – 1-1/8")	3 – 30 mm thick (1/8" – 1-1/8") H	—	—	Ideal for cutting thin materials.
No. B-16	5 – 60 mm thick (13/64" – 2-3/8")	5 – 60 mm thick (13/64" – 2-3/8") S	—	—	For fast cutting.
No. B-17	5 – 60 mm thick (13/64" – 2-3/8")	5 – 60 mm thick (13/64" – 2-3/8") S	—	—	Ideal for scroll cutting.
No. B-18	2 – 30 mm thick (5/64" – 1-1/8")	2 – 30 mm thick (5/64" – 1-1/8") S	—	—	Ideal for scroll cutting.
No. B-19	3 – 30 mm thick (1/8" – 1-1/8")	3 – 30 mm thick (1/8" – 1-1/8") H	—	—	Cuts on down stroke. Splinter-free on finish side.
No. B-21	—	3 – 55 mm thick (1/8" – 2-1/8") H	3 – 10 mm thick (1/8" – 3/8")	—	For finish work, especially in plastics.
No. B-22	—	1.5 – 3 mm thick (1/16" – 1/8") H	1 – 6 mm thick (3/64" – 1/4")	1 – 3 mm thick (3/64" – 1/8")	Also ideal for cutting stainless steel.
No. B-23	—	3 – 6 mm thick (1/8" – 1/4") H	3 – 10 mm thick (1/8" – 3/8")	3 – 6 mm thick (1/8" – 1/4")	Also ideal for cutting stainless steel.
No. B-24	—	1 – 3 mm thick (3/64" – 1/8") H	0.5 – 3 mm thick (1/64" – 1/8")	0.5 – 2 mm thick (1/64" – 5/64")	Also ideal for cutting stainless steel.
No. B-25	3 – 55 mm thick (1/8" – 2-1/8") H	3 – 55 mm thick (1/8" – 2-1/8") H	3 – 30 mm thick (1/8" – 1-1/8")	3 – 10 mm thick (1/8" – 3/8")	Ideal for cutting thick materials.
No. B-26	3 – 55 mm thick (1/8" – 2-1/8") H	3 – 55 mm thick (1/8" – 2-1/8") H	3 – 30 mm thick (1/8" – 1-1/8")	3 – 10 mm thick (1/8" – 3/8")	Ideal for scroll cutting.
No. B-27	—	1.5 – 3 mm thick (1/16" – 1/8") H	1 – 6 mm thick (3/64" – 1/4")	1 – 3 mm thick (3/64" – 1/8")	Ideal for scroll cutting.

NOTE:

"H" stands for hard materials

"S" stands for soft materials

ELECTRONIC JIG SAW Model 4303C

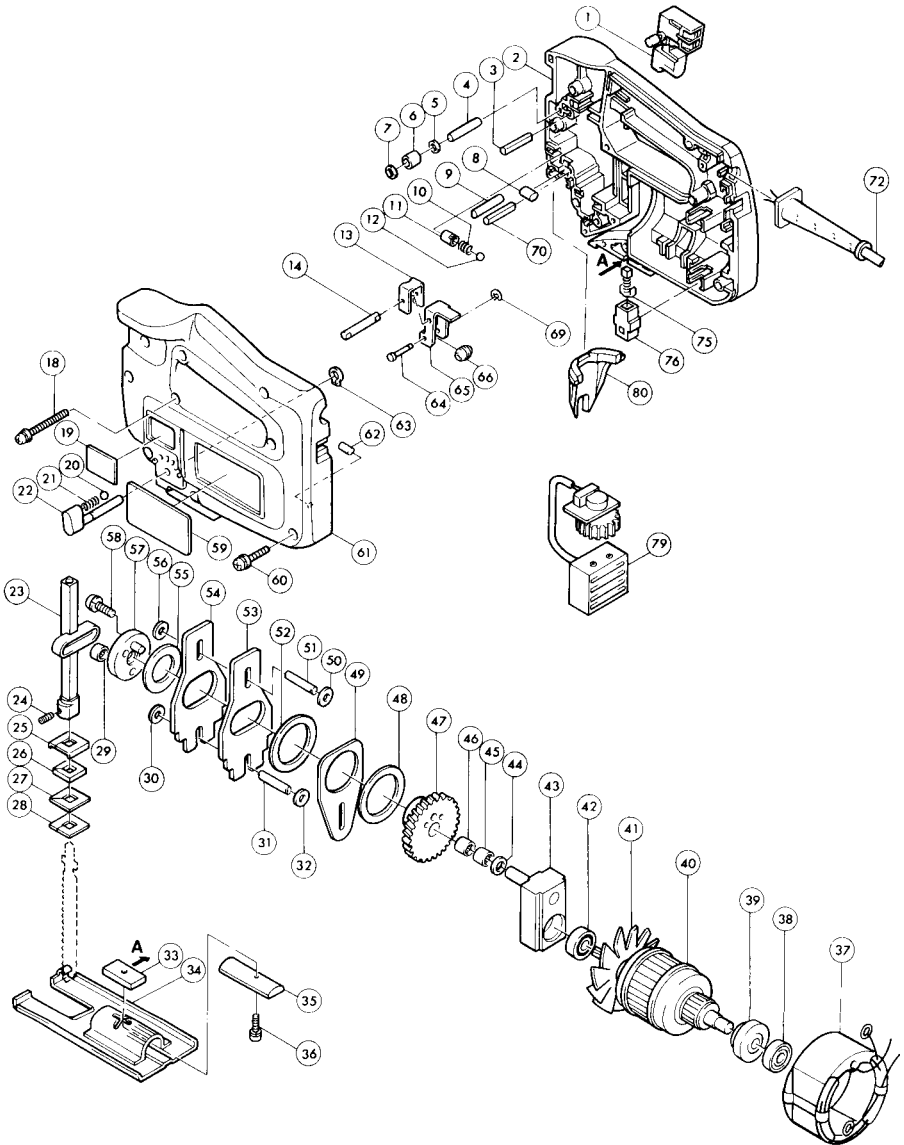

Note: The switch and other part configurations may differ from country to country.

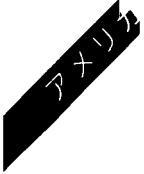

ITEM NO.	NO. USED	DESCRIPTION	ITEM NO.	NO. USED	DESCRIPTION
MACHINE			MACHINE		
1	1	Switch	41	1	Fan 68
2	1	Housing Set (With Item 61)	42	1	Ball Bearing 608LB
3	1	Pin 5	43	1	Bearing Case
4	1	Pin 5	44	1	Flat Washer 8
5	1	Flat Washer 5	45	1	Needle Bearing 810
6	1	Roller	46	1	Needle Bearing 810
7	1	Flat Washer 5	47	1	Helical Gear 65
8	4	Pin 6	48	1	Flat Washer 35
9	1	Pin 5	49	1	Push Plate
10	1	Compression Spring 4	50	1	Flat Washer 6
11	1	Spring Guide	51	1	Pin 6
12	1	Steel Ball 5 6	52	1	Flat Washer 35
13	1	Spacer	53	1	Balance Plate
14	1	Pin 4	54	1	Balance Plate
18	3	Pan Head Screw M5x45 (With Washer)	55	1	Flat Washer 26
19	1	Label	56	1	Flat Washer 6
20	1	Steel Ball 4	57	1	Crank
21	1	Compression Spring 4	58	2	Pan Head Screw M5x16 (With Washer)
22	1	Lever 25	58	1	Name Plate
23	1	Slider	60	6	Pan Head Screw M5x25 (With Washer)
24	1	Hex. Socket Head Bolt M6x8	61	1	Housing Set (With Item 2)
25	1	Dust Plate	62	1	Rubber Pin 4
26	1	Dust Seal	63	1	Retaining Ring S 6
27	1	Thin Washer 9	64	1	Pin 4
28	1	Fiber Washer 9	65	1	Retainer
29	1	Needle Bearing 607	66	1	Roller
30	1	Flat Washer 6	67	1	Sponge Sheet
31	1	Pin 5	68	1	Dust Plate
32	1	Flat Washer 6	69	1	Stop Ring E 3
33	1	Base Holder	70	1	Pin 5
34	1	Base	72	1	Cord
35	1	Clamp Plate	75	2	Carbon Brush
36	1	Hex. Socket Head Bolt M4x16 (With Washer)	76	2	Brush Holder
37	1	FIELD ASSEMBLY	79	1	Controller
38	1	Ball Bearing 608LB	80	1	Protector
39	1	Insulation Washer			
40	1	ARMATURE ASSEMBLY (With Item 38 42)			

Note: The switch and other part specifications may differ from country to country.

MAKITA LIMITED ONE YEAR WARRANTY

Warranty Policy

Every Makita tool is thoroughly inspected and tested before leaving the factory. It is warranted to be free of defects from workmanship and materials for the period of ONE YEAR from the date of original purchase. Should any trouble develop during this one-year period, return the COMPLETE tool, freight prepaid, to one of Makita's Factory or Authorized Service Centers. If inspection shows the trouble is caused by defective workmanship or material, Makita will repair (or at our option, replace) without charge.

This Warranty does not apply where:

- repairs have been made or attempted by others;
- repairs are required because of normal wear and tear;
- The tool has been abused, misused or improperly maintained;
- alterations have been made to the tool.

IN NO EVENT SHALL MAKITA BE LIABLE FOR ANY INDIRECT, INCIDENTAL OR CONSEQUENTIAL DAMAGES FROM THE SALE OR USE OF THE PRODUCT. THIS DISCLAIMER APPLIES BOTH DURING AND AFTER THE TERM OF THIS WARRANTY.

MAKITA DISCLAIMS LIABILITY FOR ANY IMPLIED WARRANTIES, INCLUDING IMPLIED WARRANTIES OF "MERCHANTABILITY" AND "FITNESS FOR A SPECIFIC PURPOSE," AFTER THE ONE-YEAR TERM OF THIS WARRANTY.

This Warranty gives you specific legal rights, and you may also have other rights which vary from state to state. Some states do not allow the exclusion or limitation of incidental or consequential damages, so the above limitation or exclusion may not apply to you. Some states do not allow limitation on how long an implied warranty lasts, so the above limitation may not apply to you.

Makita Corporation
 3-11-8, Sumiyoshi-cho,
 Anjo, Aichi 446 Japan

883885 - 069

PRINTED IN JAPAN

1994 - 6 - N